

HYDROSTATIC STEERING UNITS TYPE HKUS.../7 - series 3

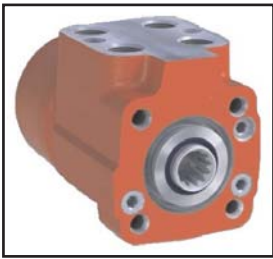

M + S Hydraulic complete its range of hydrostatic steering units .
 These products are with built-in shock valves, while fully covering the parameters of the current HKU../7.
 The application is for integration into systems with built-in hydroaccumulator, achieving minimal energy losses.

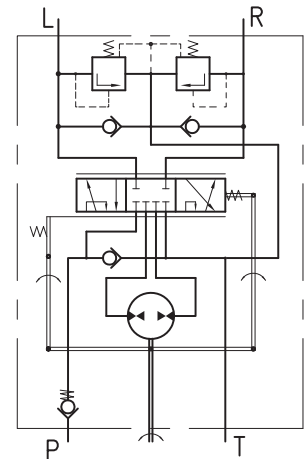

"Close Center - Non Load Reaction"
 HKUS.../7 ser.3

SPECIFICATION DATA

Parameters	Type											
	HKUS 40/7	HKUS 50/7	HKUS 63/7	HKUS 80/7	HKUS 100/7	HKUS 125/7	HKUS 160/7	HKUS 200/7	HKUS 250/7	HKUS 320/7	HKUS 400/7	
Displacement cm ³ /rev [in ³ /rev]	39,6 [2.42]	49,5 [3.0]	65,6 [4.0]	79,2 [4.83]	99,0 [6.04]	123,8 [7.56]	158,4 [9.67]	198 [12.1]	247,5 [15.1]	316,8 [19.3]	396 [24.2]	
Rated Flow* lpm [GPM]	4 [1.1]	5 [1.3]	6 [1.6]	8 [2.1]	10 [2.6]	13 [3.4]	16 [4.2]	20 [5.3]	25 [6.6]	32 [8.4]	40 [10.6]	
Rated Pressure bar [PSI]	125 [1813]	140 [2030]	170 [2465]									
Shock Valve Pressure** bar [PSI]	220 [3190]											
Max. Cont. Pressure in Line T - standard - high pressure (H option) bar [PSI]	25 [363] 40 [580]											
Max. Torque at Servoamplifying - with standard springs - with soft springs (LT option) Nm [lb-in]	3,0 [26] 1,8 [16]									3,0 [26] -		
Max. Torque w/o Servoamplifying Nm [lb-in]	120 [1065]											
Weight kg [lb]	5,3 [11.7]	5,4 [11.9]	5,5 [12.2]	5,6 [12.4]	5,7 [12.6]	5,8 [12.8]	6,0 [13.2]	6,3 [13.9]	6,5 [14.3]	7,0 [15.4]	7,4 [16.3]	
Dimension A mm [in]	130,8 [5.15]	132,2 [5.20]	134,2 [5.27]	136,2 [5.36]	138,8 [5.47]	142,2 [5.60]	146,8 [5.78]	152,2 [5.99]	158,8 [6.25]	168,2 [6.62]	178,8 [7.04]	

* Rated Flow at 100 RPM.

** Pressure Settings are at flow rate of 2 lpm [.53GPM] and viscosity 21 mm²/s [105 SUS] at 50°C [122°F].

DIMENSIONS AND MOUNTING DATA - HKUS.../7 - series 3

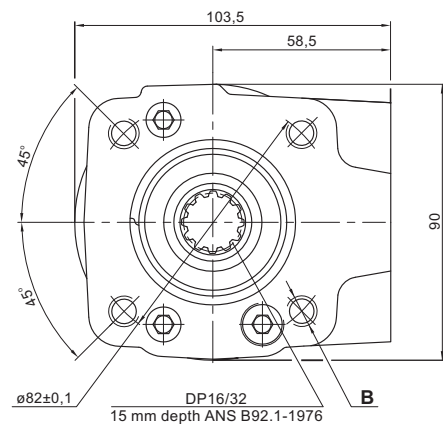
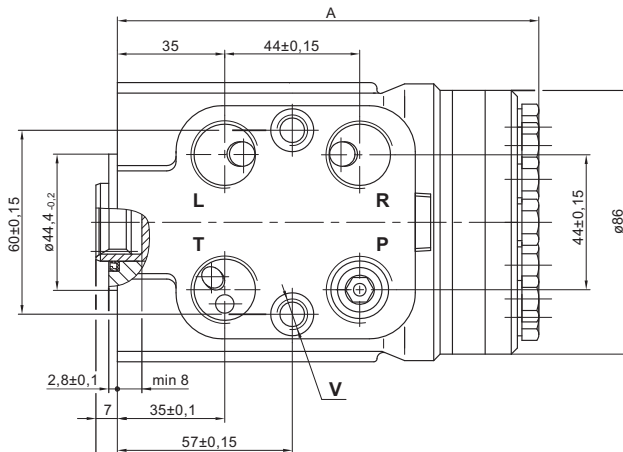

THREADED PORTS



Code	Ports - *P, T, R, L Thread	Column Mounting Thread - B	Valve Mounting Thread - V
-	G1/2 17 mm depth	4 x M10 16 mm depth	2 x M10x1 16 mm depth
M	M22x1,5 17 mm depth	4 x M10 16 mm depth	2 x M10x1 16 mm depth
MBO	M18x1,5 O-ring 17 mm depth	4 x M10 16 mm depth	2 x M10x1 16 mm depth
A	3/4 - 16UNF O-ring 17 mm depth	4 x 3/8 - 16 UNC 16 mm depth	2 x 3/8 - 24 UNF 14,2 mm depth

*Threaded Port P min 15 mm.

ORDER CODE

1	2	3	4	5	6	7	8
HKUS	/	-				/	3

Pos.1 - Displacement code (see Specification Data)

40	- 39,6 cm ³ /rev [2.42 in ³ /rev]
50	- 49,5 cm ³ /rev [3.00 in ³ /rev]
63	- 65,6 cm ³ /rev [4.00 in ³ /rev]
80	- 79,2 cm ³ /rev [4.83 in ³ /rev]
100	- 99,0 cm ³ /rev [6.04 in ³ /rev]
125	- 123,8 cm ³ /rev [7.56 in ³ /rev]
160	- 158,4 cm ³ /rev [9.67 in ³ /rev]
200	- 198,0 cm ³ /rev [12.10 in ³ /rev]
250	- 247,5 cm ³ /rev [15.10 in ³ /rev]
320	- 316,8 cm ³ /rev [19.30 in ³ /rev]
400	- 396,0 cm ³ /rev [24.20 in ³ /rev]

Pos.2 - Versions

7 - Version 7 "Closed Center - Non Load Reaction"

Pos.3 - Ports

omit	- BSPP (ISO 228)
A	- SAE (ANSI B 1.1 - 1982)
M	- Metric (ISO 262)
MBO	- Metric (ISO 6149-1)

Pos.4 - Max. Cont. Pressure in line T

omit	- Standard
H	- High pressure

Pos.5 - Input torque

omit	- Standard
LT*	- Low

Pos.6 - Noise level

omit	- Standard
LN*	- Low

Pos.7 - Option (Paint)***

omit	- No Paint
P	- Painted
PC	- Corrosion Protected Paint
PS	- Special Paint****
PCS	- Special Corrosion Protected Paint****

Pos.8 - Design Series

omit	- Factory specified
------	---------------------

Notes: * Available only for displacement from 40 to 200.
** Colour at customer's request.
*** Non painted feeding surfaces.

If a painting option is required, the standard color is black Alkyd-styrenated enamel, Black RAL 9005.

The steering units are mangano-phosphatized as standard.